

Quick Installation Guide

Network Video Recorder

*Images may differ from actual products.

1 Package Contents

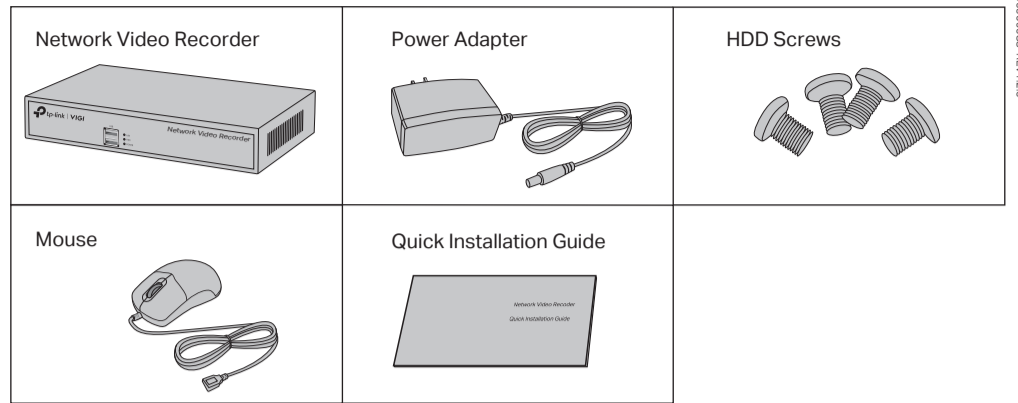

2 Product Overview

Front Panel

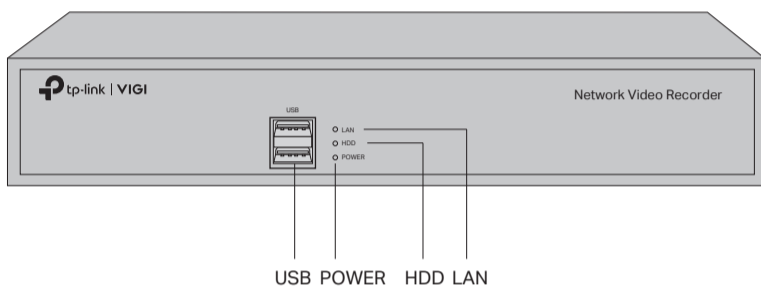

Indicator	Name	Status	Description
LAN	Network Status Indicator	On	Network is working properly.
		Flashing	Data is being transmitted or received.
		Off	The network is malfunctioning.
HDD	Hard Disk Drive Indicator	On	The HDD is normal.
		Off	No HDD or the HDD is malfunctioning.
POWER	Power Status Indicator	On	The NVR is on.
		Off	The NVR is off.

Back Panel

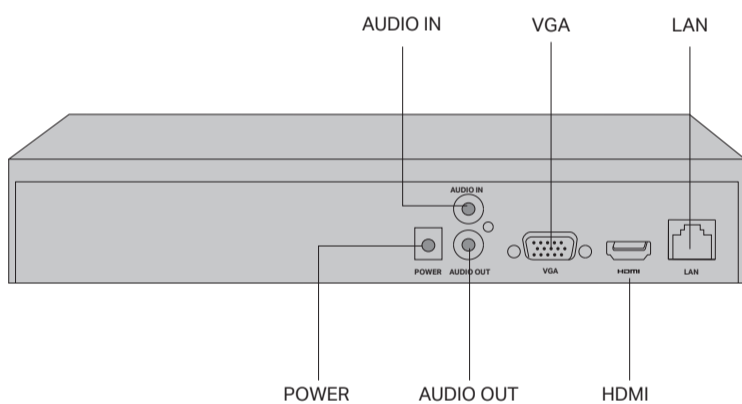

Interface	Description
USB (Front Panel)	2 USB ports for additional devices* such as USB mouse, USB storage device, and USB keyboard.
POWER	Connector for power input.
AUDIO IN / AUDIO OUT	Connector for audio input and output. Note: Audio input only supports microphones with power supply.
VGA	Output port for analog video signals. Connect your monitor to this port if it uses VGA connection.
HDMI	Output port for high-definition audio and video signals. Connect your monitor to this port if it uses HDMI connection.
LAN	RJ45 10/100Mbps self-adaptive Ethernet port. Connect to an Ethernet device (eg. router and switch).

3 Hard Drive Installation

For the first time installation, please prepare a 3.5-inch hard disk drive (HDD). It is recommended to use the HDD of surveillance or enterprise level. Before installation, please disconnect the power from the network video recorder (NVR).

1. Remove the fixing screws on the side and back panels to open the cover of the NVR.

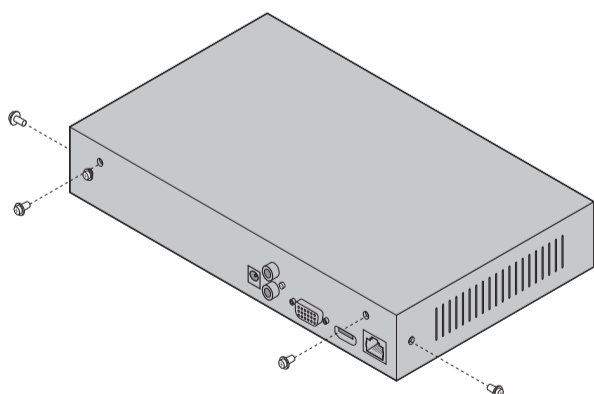

2. Attach the 4 included HDD screws to your hard drive. Do not fasten.

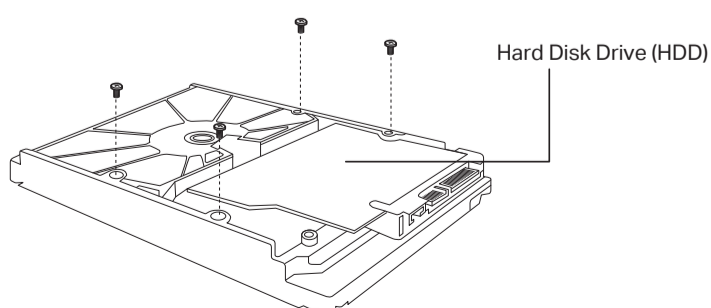

3. Match the 4 screws on the HDD with the 4 holes on the NVR, and insert the HDD interface into the slot.

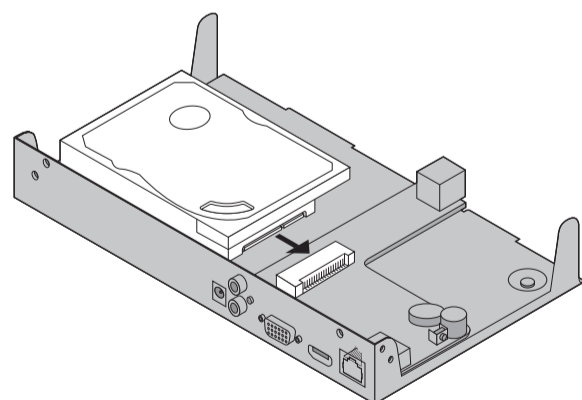

4. Flip the NVR upside down and fasten the HDD screws. Replace the cover and fasten the screws of the NVR.

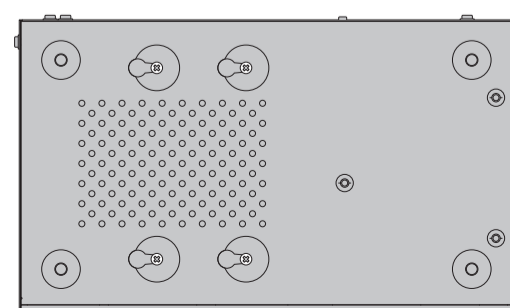

4 Hardware Connection

Follow the steps below to complete the hardware connection.

1. Connect your monitor to the HDMI or VGA port according to the connection port it supports.
2. Connect your monitor to a power source and turn it on.
3. Connect the LAN port of the NVR to a network device with an Ethernet cable.
4. Connect the provided USB Mouse to the USB Interface of the NVR (front panel).
5. Connect the power adapter to the NVR.

⚠ Cautions

- If you want to turn off the NVR after installing the hard drive, right click on the Live View screen and click the Power button  on **Main Menu** of your monitor. Do not unplug it directly.
- The input voltage should match the power requirements of the NVR.
- The buzzer on the NVR may be triggered when no hard drive is installed or the hard drive in the NVR hasn't been initialized.

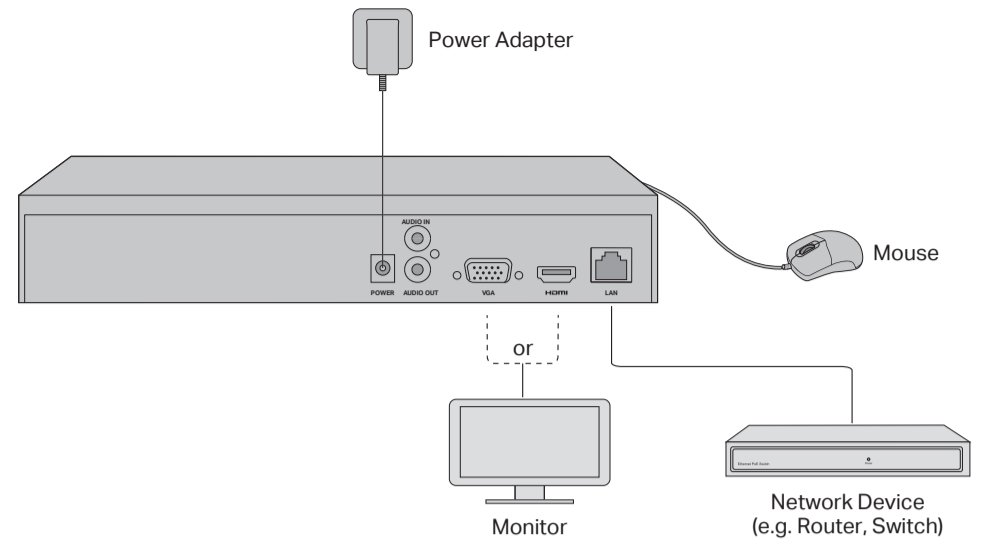

5 Configuration

NVR can add and manage cameras in batches.

* Here we use TP-Link cameras as an example. For other camera brands, please refer to their User Manuals to add the cameras.

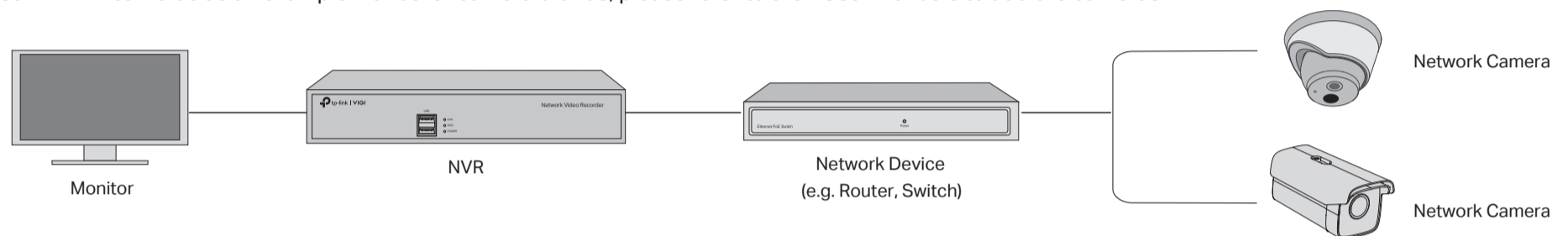

Step 1. Connect your cameras to the same network as your NVR.

Step 2. Follow the instructions to finish Quick Setup.

1. Create a login password for the NVR and a preset password for your unset cameras.
Note: Enter an email address for resetting the password of NVR or cameras.
2. Enable **Plug and Play** and the NVR will automatically find and add the cameras in your network.
3. Follow **Quick Setup** to complete the settings of the NVR.

Step 3. Right click on the Live View screen to open the Main Menu for management.

(Optional) Step 4. Bind your NVR to a TP-Link ID for remote access and management.

1. Right click on the Live View screen and click **Settings**.
2. Click **Cloud Services** on the top, enter your TP-Link ID and password, and click **Bind**.

Note:

- Make sure your NVR can get access to the internet before binding.
- If you don't have a TP-Link ID, sign up first.
- If your NVR fails to connect to the Internet, please refer to **FAQ-Q3**.
- For more instructions, please refer to the NVR's User Guide.

If you want to add a camera after Quick Setup, please follow the steps below:

1. Right click on the Live View screen and click **Add Camera**.
2. Select a camera and click **+** to add your camera directly. If you have disabled **Plug and Play** on your NVR, please create a password or use the preset password for your unset camera.

Note:

- The password set for cameras in **Quick Setup** will be applied to your unset cameras.
- If your cameras have been activated, use the previous passwords to add and manage the cameras.
- If you can't find your camera, refer to **FAQ-Q2**.

More Management Methods

You can add and manage your devices via any of the methods below.

Method 1: Via the VIGI Security Manager (Windows only)

View live video and modify NVR settings on your computer.

1. Download the **VIGI Security Manager** on your computer at <https://www.tp-link.com/support/download/vigi-security-manager/>.
2. Install the **VIGI Security Manager** and open it.
3. NVR on the same network as your computer can be automatically discovered. Go to **Settings > Discovered Devices**, click **Add**, and follow the instructions to add your NVR.

Method 2: Via the TP-Link VIGI App

Remotely view live video, manage NVR, and get instant alerts.

1. Download and install the **TP-Link VIGI** app.



2. Open the app and log in with your TP-Link ID. If you don't have an account, sign up first.
3. Tap the **+** button on the top right and follow the app instructions to add your NVR.

Frequently Asked Questions

Q1. What should I do if I forget the login password of my NVR?

- A1. Click **Forgot Password** on the login page and then follow the instructions to reset the password.
- A2. Remove the cover, then press and hold the Reset button inside the NVR for over 3 seconds. The NVR will restore to the factory settings. Then follow **Quick Setup** to create a login password.

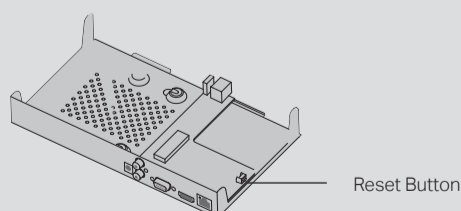

Q2. What can I do if no cameras are found?

- A1. Refresh to discover your cameras again.
- A2. Make sure the cameras are powered on.
- A3. Make sure your cameras and NVR or computer are in the same network.
- A4. Try to add your cameras manually.

Q3. What can I do if my NVR fails to connect to the Internet?

- A1. Check if the internet is working properly.
- A2. Make sure your NVR is in the same network segment as your network devices. For more details, please refer to the NVR's User Guide.

If you have more questions, please visit <https://www.tp-link.com/support/faq/2850/>.

Safety Information

- Keep the device away from water, fire, humidity or hot environments.
- Do not attempt to disassemble, repair, or modify the device.
- Do not use damaged charger or USB cable to charge the device.
- Do not use any other chargers than those recommended.
- Adapter shall be installed near the equipment and shall be easily accessible.
- Use only power supplies which are provided by manufacturer and in the original packing of this product. If you have any questions, please don't hesitate to contact us.
- Avoid disposal of a battery into fire or a hot oven, or mechanically crushing or cutting of a battery, that can result in an explosion.
- Place the device with its bottom surface downward. Install it at stable places, and prevent it from falling.
- CAUTION: RISK OF EXPLOSION IF BATTERY IS REPLACED BY AN INCORRECT TYPE. DISPOSE OF USED BATTERIES ACCORDING TO THE INSTRUCTIONS.
- *Some devices may be incompatible, such as wireless mouse.

Please read and follow the above safety information when operating the device. We cannot guarantee that no accidents or damage will occur due to improper use of the device. Please use this product with care and operate at your own risk.

TP-Link hereby declares that the device is in compliance with the essential requirements and other relevant provisions of directives 2014/30/EU, 2014/35/EU, 2009/125/EC, 2011/65/EU and (EU)2015/863.

The original EU declaration of conformity may be found at <https://www.tp-link.com/en/ce>

For technical support, the user guide and other information, please visit <https://www.tp-link.com/support>, or simply scan the QR code.

To ask questions, find answers, and communicate with TP-Link users or engineers, please visit <https://community.tp-link.com> to join TP-Link Community.

If you have any suggestions or needs on the product guides, welcome to email techwriter@tp-link.com.cn.

The terms HDMI, HDMI High-Definition Multimedia Interface, and the HDMI Logo are trademarks or registered trademarks of HDMI Licensing Administrator, Inc.

